

PART C

Moment Resisting Frames with Infill Panels

C7

Non-EPB Seismic Assessment Guidelines

**ONLY TO BE USED FOR SEISMIC ASSESSMENTS
OUTSIDE THE EPB METHODOLOGY**

2025



Foreword

The Joint Committee for Seismic Assessment and Retrofit of Existing Buildings is responsible for the joint oversight of the system used to assess, communicate, manage and mitigate seismic risk in existing buildings. It reviews how the guidelines are functioning in practice, identifies areas that require further input and development, and either advises on or assists in the development of proposals for work programmes that contribute towards these objectives. The Joint Committee includes representatives from The Natural Hazards Commission Toka Tū Ake, the Ministry of Business, Innovation & Employment, and the technical societies (NZGS, NZSEE, SESOC).

The Joint Committee's Vision is that:

- Seismic retrofits are being undertaken when necessary to reduce our seismic risk over time while limiting unnecessary disruption, demolitions and carbon impacts, promoting continued use or re-use of buildings.
- Decisions on retrofitting are informed by an appropriate understanding of seismic risk and are aligned with longer term asset planning.
- Seismic assessment and retrofit guidelines help engineers focus on the most critical vulnerabilities in a building, serve the needs of the market and regulation, and evolve through a stable ongoing cycle allowing new knowledge and improvements to be included in a predictable manner, including the consideration of objectives beyond life safety.
- Engineers are supported in the implementation of Seismic Assessment and Retrofit Guidelines through a range of training and information sharing strategies, including tools for risk communication to manage unnecessary vacating of buildings.
- Society is informed about the level of risk posed by existing buildings.

Acknowledgements

Updates encompassed in this document were prepared by the Joint Committee in conjunction with a Technical Review Group formed for the *Concrete Buildings C5+* project.

Joint Committee		Technical Review Group
Nic Brooke	SESOC	Nic Brooke (Editor)
Dave Brunsdon	SESOC	Carl Ashby
Caleb Dunne	NHC	Des Bull
Ken Elwood	MBIE/NHC	Rick Henry
Rob Jury	NZSEE	Stuart Oliver
Stuart Palmer	NZGS	Umair Siddiqui
Mark Ryburn	MBIE	Craig Stevenson
Henry Tatham	NZSEE	Weng Yuen Kam
Merrick Taylor	NZGS	
Andy Thompson	NZSEE	

Version Record

Version	Date	Purpose/ Summary of changes
1	17 July 2017	Initial release
2A	17 March 2025	Proposed technical revision only for use for non-Earthquake Prone Building purposes.

This document is managed by the Joint Committee for Seismic Assessment and Retrofit of Existing Buildings. It may be downloaded from design.resilience.nz.

Refer to the following pages for a summary of the key changes from previous versions.

Please visit design.resilience.nz to provide feedback or to request further information about these Guidelines.

Copyright

The copyright owner authorises reproduction of this work, in whole or in part, so long as no charge is made for the supply of copies and the integrity and attribution of the contributors and publishers of the document is not interfered with in any way.

Where the material is being published or issued to others, the source and copyright status should be acknowledged.

The permission to reproduce copyright material does not extend to any material in this report that is identified as being the copyright of a third party. Authorisation to reproduce such material should be obtained from the copyright holders.

Disclaimer

This document is intended as a guideline only. This document is intended for use by trained practitioners under appropriate supervision and review. Practitioners must exercise professional skill and judgement in its application.

This document has not been released under Section 175 of the Building Act. While care has been taken in preparing this document, it should not be used as a substitute for legislation or legal advice.

It is not mandatory to use the information in this document, but if used:

- This document does not relieve any person or consenting authority of the obligation to conduct their own professional enquiries, research or assessments, and to exercise their own independent judgement, according to the circumstances of the particular case;
- Consenting authorities are not bound to accept the information as demonstrating compliance with any relevant Acts, Codes or Standards.

Neither the Joint Committee, nor any of its member organisations, nor any of their respective employees, is responsible for any actions taken on the basis of information in this document, or any errors or omissions.

Users of information from this publication assume all liability arising from such use.

By continuing to use the document, a user confirms that they agree to these terms

This section is part of the *Non-EPB (Earthquake-Prone Building) Seismic Assessment Guidelines* which constitute a proposed technical revision to the 1 July 2017 [EPB Seismic Assessment Guidelines](#). The *Non-EPB Seismic Assessment Guidelines* may be used for general commercial Detailed Seismic Assessments for non-EPB purposes. It is to be used in conjunction with Part A of the *EPB Seismic Assessment Guidelines*.

Engineers engaged to assess buildings identified by a territorial authority as being potentially earthquake prone in accordance with the *EPB Methodology* must continue to use *EPB Seismic Assessment Guidelines* (1 July 2017) as these are referenced in the Methodology.

Summary of Key Changes from Version 1

A limited revision of Section C7 has been undertaken. The motivation for this revision was to correct inconsistencies with updated versions of Section C5: Concrete Buildings. Errors identified in Version 1 have also been corrected, and updated references provided.

Contents

C7. Moment Resisting Frames with Infill Panels C7-1

C7.1 General.....	C7-1
C7.1.1 Scope and outline of this section	C7-1
C7.1.2 Useful publications	C7-1
C7.1.3 Definitions and acronyms	C7-2
C7.1.4 Notation, symbols and abbreviations	C7-3
C7.2 Typical Building Practices in New Zealand.....	C7-5
C7.3 Factors Affecting Seismic Performance of Masonry Infill Panels and Buildings Containing Them	C7-8
C7.4 Observed Seismic Behaviour of Masonry Infill Panels and Buildings Containing Them	C7-10
C7.5 Material Properties	C7-12
C7.5.1 Clay brick masonry	C7-12
C7.5.2 Concrete block masonry.....	C7-12
C7.5.3 Reinforced concrete	C7-12
C7.5.4 Structural steel	C7-12
C7.6 Assessment of Masonry Infill for Out-of-Plane Actions	C7-13
C7.6.1 Probable out-of-plane strength.....	C7-13
C7.6.2 Out-of-plane demands.....	C7-15
C7.7 Assessment of Masonry Infill for In-Plane Actions.....	C7-16
C7.7.1 Modelling of infill panels	C7-16
C7.7.2 Probable in-plane strength	C7-20
C7.7.3 Generalised strength-deformation relationships	C7-22
C7.8 Influence of Infill Panels on Frame Members	C7-24
C7.8.1 General.....	C7-24
C7.8.2 In-plane shear demands on columns adjacent to solid infill panels	
C7.8.3 In-plane shear demands on columns adjacent to partial height infill panels	C7-25
C7.8.4 In-plane shear demands on beams adjacent to solid infill panels	C7-25
C7.8.5 In-plane shear demands on beams and columns adjacent to perforated infill panels.....	C7-26
C7.8.6 In-plane tension demands on beam to column connections.....	C7-27
C7.8.7 Modified shear capacity.....	C7-27
C7.8.8 Bond slip of lap-splice connections in reinforced concrete frame members.....	C7-27
C7.9 Improving the Seismic Performance of Moment Resisting Frames with Masonry Infill Panels	C7-28
C7.9.1 Improving out-of-plane performance	C7-28
C7.9.2 Improving in-plane performance	C7-28
References.....	C7-29

C7. Moment Resisting Frames with Infill Panels

C7.1 General

C7.1.1 Scope and outline of this section

This section sets out the guidelines for the seismic assessment of structural steel or reinforced concrete moment resisting frames with masonry infill panels, with or without openings. Infill panels can consist of:

- unreinforced clay brick masonry
- hollow clay brick masonry (which can be filled or unfilled, reinforced or unreinforced), or
- concrete block masonry (which can be solid or hollow; unfilled, partially filled or fully filled; and reinforced or unreinforced).

These guidelines are valid for walls in good condition with negligible mortar joint cracking or brick splitting other than some minor damage due to settlement or similar factors which, by observation, are unlikely to be detrimental to their performance during an earthquake.

The assessment procedures presented cover in-plane effects on the frame elements and the panel and also the assessment of face-loaded capacities.

Note:

Frames with infill panels have been used in New Zealand since the early 1920s. Masonry infill panels modify the seismic response of the adjacent frame elements in terms of stiffness, the nature of the applied loads and local ductility demands.

Many of the behaviour issues associated with frames with infill panels arise from discontinuities of infill, resulting in soft storeys or non-uniform distribution of storey stiffness. This in turn leads to a high concentration of seismic loading to be transferred amongst the associated elements. Consequently, if infill panels are present in a building, it is important that their influence on its seismic performance is explicitly considered.

C7.1.2 Useful publications

Useful information on materials, inspection and assessment of infill frames is contained in:

ASCE 41-13 (2014). *Seismic evaluation of existing buildings*, American Society of Civil Engineers and Structural Engineering Institute, Reston, Virginia, USA.

FEMA 306 (1998). *Evaluation of earthquake damaged concrete and masonry wall buildings – Basic Procedures Manual*, Applied Technology Council, Redwood City, California.

Flanagan, R.D. and Bennett, R.M. (1999). *Arching of masonry infilled frames: comparison of analytical methods*, ASCE Practice Periodical on Structural Design and Construction, 4(3), 105-110.

Flanagan, R.D. and Bennett, R.M. (2001). *In-plane analysis of masonry infill panels*, Practice Periodical on Structural Design and Construction, American Society of Civil Engineers, Reston, Virginia.

[Gentile, R., Pampanin, S., Raffaele, D., and Uva, G. \(2019a\). "Non-linear analysis of RC masonry-infilled frames using the SLaMA method: part 1—mechanical interpretation of the infill/frame interaction and formulation of the procedure." *Bulletin of Earthquake Engineering*, 17\(6\), pp.3283–3304.](#)

[Gentile, R., Pampanin, S., Raffaele, D., and Uva, G. \(2019b\). "Non-linear analysis of RC masonry-infilled frames using the SLaMA method: part 2—parametric analysis and validation of the procedure." *Bulletin of Earthquake Engineering*, 17\(6\), pp.3305–3326.](#)

MSJC (2011). TMS 402-11: *Building code requirements for masonry structures*, Masonry Joint Standards Committee, Reston, Virginia.

Stavridis, A. (2009). *Analytical and experimental study of seismic performance of reinforced concrete frames with masonry walls*, PHD Dissertation, University of California, San Diego.

Turgay, T., Durmus, M.C., Binici, B. and Ozcebe, G. (2014). *Evaluation of the predictive models for stiffness, strength and deformation capacity of RC frames with masonry infill walls*, *ASCE Journal of Structural Engineering*, 06014003, 1-9.

C7.1.3 Definitions and acronyms

Action	Set of concentrated or distributed forces acting on a structure (direct action), or deformation imposed on a structure or constrained within it (indirect action). The term 'load' is also often used to describe direct actions.
Beam	A member subjected primarily to loads producing flexure and shear
Column	A member subjected to loads producing flexure shear and axial actions
Dead load	The weight of the building materials that make up a building, including its structure, enclosure and architectural finishes. The dead load is supported by the structure (walls, floors and roof).
Ductile/ductility	Describes the ability of a structure to sustain its load-carrying capacity and dissipate energy when it is subjected to cyclic inelastic displacements during an earthquake
Face-loaded walls	Walls subjected to out-of-plane inertial forces. Also see Out-of-plane load.
Gravity load	The load applied in a vertical direction, including the weight of building materials (dead load), environmental loads such as snow, and building contents (live load)
Infill panel	A panel of masonry bounded by beams and columns and constructed partially or fully within the plane of a steel or reinforced concrete frame
Infill wall	See infill panel
In-plane load	Load acting along the wall length
Irregular building	A building that has an irregularity that could potentially affect the way in which it responds to earthquake shaking. A building that has a sudden change in its plan shape is considered to have a horizontal irregularity. A building that changes shape up its height (such as one with setbacks or overhangs) or that is missing significant load-bearing elements is considered to have a vertical irregularity. Structural irregularity is as defined in NZS 1170.5:2004.
Lateral load	Load acting in the horizontal direction, which can be due to wind or earthquake effects
Load	See Action
Masonry	Any construction in units of clay, stone or concrete laid to a bond and joined together with mortar
Moment resisting frame (MRF)	A building frame system in which lateral loads are resisted by shear and flexure in members and joints of the frame
Mortar	The cement/lime/sand mix in which masonry units are bedded
Out-of-plane load	Load acting at right angles to the wall surface. Walls subjected to out-of-plane shaking are referred to as face-loaded walls.
Soft storey	A level (storey) in a multi-storey building which is weaker than the levels above

Wythe	A continuous vertical section of masonry one unit in thickness. A wythe may be independent of, or interlocked with, the adjoining wythe(s).
-------	---

C7.1.4 Notation, symbols and abbreviations

Unless otherwise stated, the notation in this section has the following meanings:

Symbol	Meaning
a	Width of equivalent diagonal compression strut
A_{op}	Area of the opening in an infill panel
A_{wtot}	Gross area of an equivalent infill panel with no openings
C	Residual strength ratio
$C_i(T_p)$	Part spectral shape coefficient from NZS 1170.5:2004. Refer to Section C3.
d	Effective member depth to the centroid of the tension reinforcing steel
d'	Effective member depth to the centroid of the compression reinforcing steel
E_{bb}	Probable moduli of elasticity of the bounding beam
E_{bc}	Probable moduli of elasticity of the bounding column
E_f	Probable modulus of elasticity of frame material
E_m	Probable modulus of elasticity of infill material
f'_m	Probable masonry compressive strength
F_{ph}	Seismic out-of-plane demands on masonry infill walls
f_y	Probable yield strength of reinforcement
h_{col}	Column height between centre lines of beam
h_{inf}	Height of infill panel
I_{bb}	Moment of inertia in the plane of the infill for the bounding beam
I_{bc}	Moment of inertia in the plane of the infill for the bounding column
j_d	Internal lever arm
K	Empirical constant
K_{ini}	Uncracked stiffness of perforated infill panel
K_{ini}^{solid}	Stiffness of an equivalent infill frame with a solid panel
l_{beff}	Effective beam length
l_{ceff}	Effective column length
L_{inf}	Length of infill panel
M_o^{beam}	Overstrength moment capacity of the beam
M_o^{col}	Overstrength moment capacity of the column
P	Axial load on the infill panel
q_{prob}	Probable uniformly distributed lateral load capacity

$q_{\text{prob}}^{\text{solid}}$	Probable uniformly distributed lateral load capacity of an equivalent infill panel with no openings
r_{inf}	Diagonal length of infill panel
t	Thickness or net thickness of infill panel depending on application. Refer particular equations
T_p	Period of a part from NZS 1170.5:2004
V_{beam}	Shear demand on reinforced concrete beam
V_{cc}	Probable corner crushing strength of the infill panel
V_{col}	Shear demand on reinforced concrete column
V_{fre}	Probable expected storey shear strength of the bare frame
V_{in}	Probable infill in-plane shear strength
V_{prob}	Probable expected in-plane strength of solid infill panel
V_s	Shear resistance provided by the steel shear reinforcement
α	Corner-to-corner crack angle measured to the axis of the member
α_{arch}	Horizontal arching coefficient
α_b	Coefficient - refer to Equation C7.25
α_c	Coefficient - refer to Equation C7.24
β	Ratio of the frame to infill strength
β_{arch}	Vertical arching coefficient
γ	In-plane cracking capacity reduction coefficient
Δ_{prob}	Probable deformation (drift deflection) capacity of masonry infill
θ	Angle whose tangent is the infill height-to-length aspect ratio
θ_b	Infill strut angle for determining reinforced concrete beam actions
θ_c	Infill strut angle for determining reinforced concrete column actions
μ_p	Ductility of the part in accordance with NZS 1170.5:2004
ρ_w	Volumetric ratio of the infill panel reinforcement

NON

C7.2 Typical Building Practices in New Zealand

Building construction comprising reinforced concrete frames with masonry infill was most common in New Zealand between the early 1920s and the mid-1960s. The style most commonly adopted at the time was for masonry infill panels along the building length transverse to the street frontage to have few or no openings, while the street frontage and rear infill walls had extensive openings (refer to Figure C7.1).



Figure C7.1: Examples of reinforced concrete frames with clay brick masonry infill (Kevin Walsh and Laura Putri)

Masonry infill walls built before the 1950s were generally made of unreinforced clay brick masonry (typically dimensioned 220 mm x 110 mm x 74 mm) mortared directly to the infill frames on all four sides (i.e. with no seismic gap) (Kam et al., 2011). These unreinforced clay brick masonry walls typically (but not always) consisted of two single wythes with a central internal air cavity and were often plastered or painted (refer to Figure C7.2).



Figure C7.2: Typical clay brick cavity infill wall construction with plaster façade and single brick removed, exposing the air cavity separating two single wythes of clay brick (Kevin Walsh)

Hollow clay brick masonry infill walls were also used in New Zealand during this period but were less common (refer to Figure C7.3).



Figure C7.3: Example of a reinforced concrete frame with terracotta masonry infill (Kevin Walsh)

Seismic gaps between the infill walls and bounding frames became more common with the adoption of the 1965 Model Building Bylaw (NZSS 1900:1965). At this point, lightly reinforced concrete block masonry (typically dimensioned 190 mm × 190 mm x 390 mm) became more popular for use as infill (refer to Figure C7.4).



Figure C7.4: Examples of reinforced concrete frames with concrete block masonry infill (Laura Putri)

Masonry infill within reinforced concrete frames became less popular with the adoption of the 1970s loading and design standards (Kam et al., 2011). However, concrete block masonry infill within steel frames continued to be used into more modern times, particularly in large storage and industrial buildings (refer to Figure C7.5).



Figure C7.5: Examples of steel frame industrial building with concrete block infill
(David Biggs)

Concrete block masonry infill walls can also be found in relatively modern reinforced concrete frame structures (i.e. built from the 1980s onwards). In these structures block infill walls are frequently used as fire rated walls, often adjacent to site boundaries. However, while these infill walls were typically separated from the adjacent columns with seismic gaps, in many instances – particularly in buildings designed before the introduction of the loadings standard NZS 4203:1992 – the width of the seismic gap will not be sufficient to accommodate significant frame deflections (refer to Section C2).

C7.3 Factors Affecting Seismic Performance of Masonry Infill Panels and Buildings Containing Them

The seismic behaviour of moment resisting frames with masonry infill is complex. If the gaps between the infill panel and the frame cannot accommodate the seismic deformations, the elements will interact. The infill panels can add considerable strength and stiffness to the system when they are behaving essentially elastically, and this can significantly alter the seismic response of a building.

For buildings located on corner sites the presence of infill panels on the non-street boundaries can result in an undesirable torsional structural response during an earthquake which may not have been anticipated in the original building design and may significantly alter the seismic demands on other elements in the building (e.g. bare frames on the street frontages).

Gaps between the infill panel and the frame can arise from:

- the construction process not providing a tight infill
- shrinkage, or
- deliberate allowance for anticipated building drifts when the building was originally designed.

If there is only a nominal gap between the frame and the infill panel (as occurs from shrinkage) the components will initially act in a fully composite fashion, as a structural wall with boundary elements. As lateral deformations increase, the behaviour becomes more complex as a result of the frame attempting to deform in a shear mode. Separation occurs between the frame and the panel at the corners on the tensional diagonal, and a diagonal compression strut develops on the compression diagonal (refer to Figure C7.6). Localised contact occurs between the frame and the panel (Paulay and Priestley, 1992).

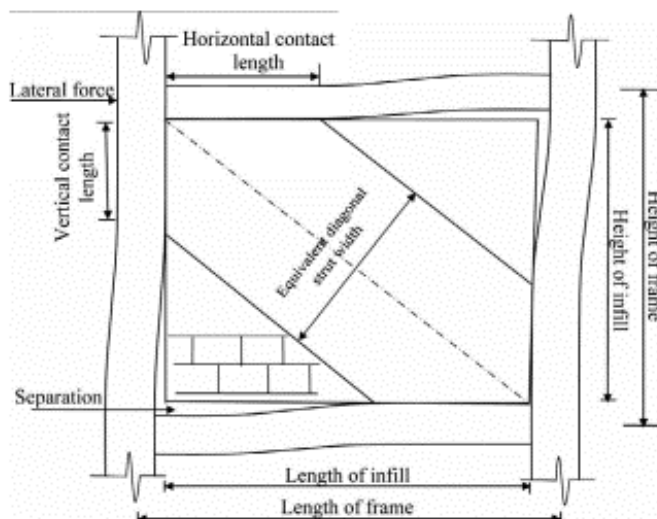

Figure C7.6: Infill frame behaviour when subject to seismic loading (Halder et al., 2013)

A number of different failure modes are possible for masonry infill frames. These include:

- tension or compression failure of the frame elements
- shear failure of the masonry infill panel
- corner crushing compression failure of the infill panel
- flexural or shear failure of the frame elements
- out-of-plane failure of the infill panel, and
- tensile failure of beam to column connections due to compressive prying action from the infill panel.

The out-of-plane performance of the infill panel itself can be significantly enhanced if the infill is tight within the frame. However, the degree of restraint provided will depend on the integrity of the mortar packing between the infill and the frame (which should always be confirmed before any reliance is placed on it).

Each of these failure modes needs to be considered when assessing the building's earthquake rating, as described below. In many situations mixed failure modes may occur. A common mixed failure mode is shear failure of the infill panel which then initiates a flexural or shear failure of the frame elements. Another commonly observed mixed failure mode is reduction of out-of-plane capacity of the infill panel due to infill panel cracking associated with in-plane demands. This is because the in-plane cracking reduces the ability of the panel to resist out-of-plane loads by arching action.

The dynamic behaviour of buildings with infill frames can change significantly during earthquakes as a result of damage sustained by the infill panels. For example, out-of-plane damage to infill panels along one side of a building could result in a torsional response which might be detrimental to the global performance of the building.

C7.4 Observed Seismic Behaviour of Masonry Infill Panels and Buildings Containing Them

Extensive damage to, and collapse of, masonry infill panels was observed during the 2009 L'Aquila earthquake sequence in central Italy. Many masonry infill panels within reinforced concrete framed buildings failed primarily due to out-of-plane mechanisms that developed because of inadequate or absent connections between the inner and outer wythes of masonry (Braga et al., 2011) and potentially poor packing between the infill and the frame (refer to Figure C7.7). Individual wythes (typically the outer wythe) often collapsed separately from their counterparts due to the high slenderness ratios associated with their non-composite response (Verderame et al., 2009).

While infill panels contributed initially to the strength and stiffness of the frame systems, in several cases soft-storey mechanisms formed during aftershocks as a result of the collapse of infill walls at the same floor level in preceding earthquakes (Augenti and Parisi, 2010).



Figure C7.7: Masonry infill frame damage observed following the 2009 L'Aquila earthquakes (Win Clarke)

By comparison, few buildings constructed with masonry infill walls experienced collapse in Christchurch during the September 2010 or February 2011 earthquakes. However, partial height masonry infills caused short column effects and corresponding reinforced concrete column shear cracking in one building, leading to partial collapse of the frame in a June 2011 aftershock (Kam et al., 2011, and also refer to Figure C7.8). Flexural-shear damage to masonry infill walls from in-plane loading was observed in some cases, while out-of-plane collapse of masonry infill was observed in at least one case.



Figure C7.8: Masonry infill frame damage observed following the 2010–2011 Canterbury earthquakes (Kam et al., 2011)

C7.5 Material Properties

C7.5.1 Clay brick masonry

Material properties for assessing the capacity of clay brick masonry infill walls can be determined in accordance with Section C8, except that the Young's modulus of clay brick masonry should be taken as:

$$E_m = 700 f'_m \quad \dots C7.1$$

where:

$$f'_m = \text{probable masonry compressive strength (MPa).}$$

Alternatively Young's modulus of clay brick masonry can be determined by field testing in accordance with Appendix C8A.

C7.5.2 Concrete block masonry

Young's modulus of concrete block masonry should be taken as:

$$E_m = 900 f'_m \quad \dots C7.2$$

where:

$$f'_m = \text{probable masonry compressive strength (MPa).}$$

C7.5.3 Reinforced concrete

Material properties for assessing the capacity of reinforced concrete frame elements can be determined in accordance with Section C5.

C7.5.4 Structural steel

Material properties for assessing the capacity of structural steel components can be determined in accordance with Section C6.

C7.6 Assessment of Masonry Infill for Out-of-Plane Actions

C7.6.1 Probable out-of-plane strength

C7.6.1.1 General

The predominant out-of-plane resisting mechanism for masonry infills is horizontal and vertical arching action. The out-of-plane resistance of masonry infill, as calculated in the equation below, is based upon an arching model of the infill in the bounding frame. Therefore, it neglects the contribution of any reinforcement that may be present in the infill in determining the out-of-plane flexural strength of participating infill.

The out-of-plane probable strength of an infill wall may be taken as:

$$q_{\text{prob}} = 730\gamma (f'_m)^{0.75} t^2 \left(\frac{\alpha_{\text{arch}}}{L_{\text{inf}}^{2.5}} + \frac{\beta_{\text{arch}}}{h_{\text{inf}}^{2.5}} \right) \quad \dots\text{C7.3}$$

where:

- q_{prob} = probable uniformly distributed lateral load capacity (kPa)
- f'_m = probable masonry compressive strength (MPa)
- h_{inf} = clear height of infill panel (mm)
- t = thickness of infill panel (mm), not to exceed $\frac{1}{8} h_{\text{inf}}$
- L_{inf} = length of infill panel (mm)
- α_{arch} = horizontal arching coefficient
- β_{arch} = vertical arching coefficient
- γ = in-plane cracking capacity reduction coefficient.

Horizontal and vertical arching coefficients can be calculated as:

$$\alpha_{\text{arch}} = \frac{1}{h_{\text{inf}}} (E_{\text{bc}} I_{\text{bc}} h_{\text{inf}}^2)^{0.25} \leq 50 \quad \dots\text{C7.4}$$

$$\beta_{\text{arch}} = \frac{1}{L_{\text{inf}}} (E_{\text{bb}} I_{\text{bb}} L_{\text{inf}}^2)^{0.25} \leq 50 \quad \dots\text{C7.5}$$

where:

- E_{bc} = probable moduli of elasticity of the bounding column (MPa)
- E_{bb} = probable moduli of elasticity of the bounding beam (MPa)
- I_{bc} = moment of inertia in the plane of the infill for the bounding column (mm^4)
- I_{bb} = moment of inertia in the plane of the infill for the bounding beam (mm^4).

In-plane cracking capacity reduction coefficient can be calculated as:

$$\gamma = 1.1 \left(1 - \frac{h_{\text{inf}}}{55t} \right) \leq 1.0 \quad \dots\text{C7.6}$$

Note:

The equation for estimating probable out-of-plane strength of masonry infill has been derived based on the work of Dawe and Seah (1989) and verified against a large experimental data set compiled and analysed by Flanagan and Bennett (1999) from seven different test programs. These included clay brick infills in concrete frames, clay tile infills in steel frames, clay brick infills in steel frames, and concrete masonry infills in steel frames. The experimental tests involved infills with height-to-thickness ratios ranging from 6.8 to 35.3, which represent the limits for use of the recommended method.

Equation C7.3 includes a capacity reduction coefficient to account for the reduction in out-of-plane strength due to prior in-plane cracking derived from a limited number of tests completed by Angel et al. (1994) on masonry infill with reinforced concrete frame elements.

When columns of different cross-sectional properties are used on either side of the infill, average properties should be used to calculate the capacity. When beams of different cross-sectional properties are used above and below the infill, average properties should be used to calculate this capacity. In the case of a single storey frame, the cross-sectional properties of the bounding beam above the infill should be used to calculate this capacity.

Allowances should be made for the effects of cracking on the cross-sectional properties of reinforced concrete frame elements when they are present. Recommended procedures in NZS 3101:2006 Concrete Structures Standard can be used to determine cross-sectional properties of reinforced concrete frame elements.

When a side gap greater than $0.02t$ is present, α_{arch} should be taken as zero. When a top gap greater than $0.02t$ is present, β_{arch} should be taken as zero.

Columns and beams with infill on both sides in the plane of the infill are likely to be flexurally rigid due to opposing arching actions from either side. Hence, values for α_{arch} and $\beta_{\text{arch}} < 50$ should generally only be applied at building corners, in top storeys, and in frame bays adjacent to portal openings.

It should be noted that q_{prob} is the resistance due to arching action of the panel as it deflects. At low loads, lateral restraint preventing the panel from moving out of the frame is necessary to enable arching action to begin.

The probable capacity of infills containing openings can be obtained using Equation C7.7:

$$q_{\text{prob}} = q_{\text{prob}}^{\text{solid}} \left(1 - \frac{A_{\text{op}}}{A_{\text{wtot}}} \right) \quad \dots\text{C7.7}$$

where:

- q_{prob} = probable uniformly distributed lateral load capacity
- $q_{\text{prob}}^{\text{solid}}$ = probable uniformly distributed lateral load capacity of an equivalent infill panel with no openings
- A_{op} = area of the opening in the infill panel
- A_{wtot} = gross area of an equivalent infill panel with no openings.

Note:

Equation C7.7 has been derived from the study reported by Mays et al. (1998), who considered yield line theory and finite element modelling for out-of-plane loads applied to concrete panels. The engineer should be aware that this equation has had limited experimental validation. In particular, the equation may not be applicable for infill panels with large openings ($A_{op}/A_{wtot} > 0.2$) when, as a consequence of the penetration size, two-way arching may not be possible.

Alternatively, a more conservative result is obtained by neglecting arching effects and using the procedures presented in Section C8 for the out-of-plane response of unreinforced masonry walls without bounding frames.

Generally, the stiffness and strength of the boundary frame will be sufficient to enable arching action to occur when the infill is subjected to out-of-plane actions, assuming the absence of side and/or top gaps between the infill and boundary frame. Once the capacity of the infill has been established taking into account horizontal or vertical arching action as appropriate, the stiffness and strength of the boundary frame should be assessed to ensure that the thrusts associated with arching action can be adequately supported and that the assumption of an approximately rigid boundary frame is valid. As no rigorous procedure has yet been developed for this assessment of the boundary frame, engineering judgement is needed based upon the specific details of the building being considered.

C7.6.1.2 Effect of reinforcement

If the infill panel is reinforced, the probable out-of-plane strength can be calculated using conventional reinforced masonry flexural theory in accordance with NZS 4230:2004 using probable material strengths and strength reduction factors equal to 1.0. In this instance beneficial effects of horizontal and vertical arching should be ignored.

C7.6.2 Out-of-plane demands

Seismic out-of-plane demands on masonry infill walls, F_{ph} , can be determined assuming the infill is a secondary structural element in accordance with Section C3.

Note:

When calculating out-of-plane seismic demands, the NZS 1170.5:2004 part spectral shape coefficient, $C_i(T_p)$, can be taken conservatively as equal to 2.0. This is because the fundamental period of vibration for most masonry infill walls, T_p , will typically be less than 0.75 sec. [The NZS 1170.5:2004 parts' ductility factor, \$\mu_p\$, should be determined in accordance with NZS 1170.5 Table C8.2 with appropriate consideration given to the ability of the infill to sustain inelastic deformations. This may be by yielding of reinforcement, rocking, sliding, or other mechanism.](#)

C7.7 Assessment of Masonry Infill for In-Plane Actions

Note:

The material in this section has largely been sourced from FEMA 306 (1998) and ASCE 41-13 (2014) with some updates to include recent research developments.

C7.7.1 Modelling of infill panels

C7.7.1.1 General

The calculation of masonry infill in-plane stiffness and strength based on nonlinear finite element analysis of a composite frame substructure with infill panels that account for the presence of openings, post-yield cracking, and cyclic degradation of masonry is permitted. Due to the complexity of the structural system resulting from the frame-infill interaction, finite element models should be validated by considering published or project-specific experimental data from cyclic quasi-static or dynamic tests.

Alternatively, the use of simplified numerical models with diagonal struts to simulate the effect of the infill detailed in Section C7.7.1.2 can be used to model infilled frames.

Note:

Refer to Stavridis (2009) and Al-Chaar et al. (2008) for additional information on the development and calibration of finite element models.

Even when significant gaps exist between infill panels and frame members, interaction can still occur between the elements. When the gap closes, the strength and stiffness of the infill frame will increase markedly. A simplified bounded approach can be used to evaluate the performance of the system. For the case when a gap still exists, the strength and stiffness of the system can be taken to be that of the bare frame. Once the gap has closed the combined strength and stiffness of the infill panel and the frame can be used.

Alternatively, compression-only nonlinear gap elements could be used to model the interaction explicitly.

The in-plane lateral stiffness of an infilled frame system is not the same as the sum of the frame and infill stiffnesses because of the interaction of the infill with the surrounding frame. Experiments have shown that, when subjected to seismic forces, small lateral deformations of the frame result in compressive contact stresses developing between the frame and the infill, with associated separation of the infill at the two diagonally opposed corners (ASCE 41-13, 2014, and refer also to Figure C7.6).

The location and orientation of the diagonal compression strut cannot be clearly defined and different geometries have been proposed:

- with struts forming along the diagonal of the frame located concentrically (refer to Figure C7.9)
- eccentrically (refer to Figure C7.10)

- at an angle of 45 degrees for infill frames with aspect ratios greater than 1.5 (refer to Figure C7.11)
- with a combination of struts to account for openings in penetrated infills (refer to Figure C7.12), or
- with a single eccentric strut for partial height infills (refer to Figure C7.13).

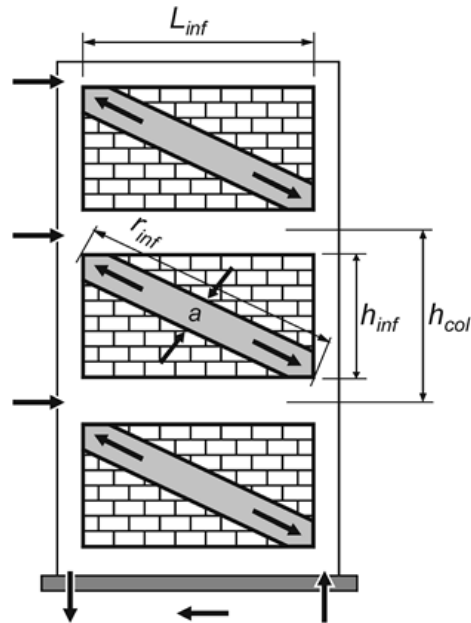

Figure C7.9: Compression strut analogy—concentric struts (ASCE 41-13, 2014)

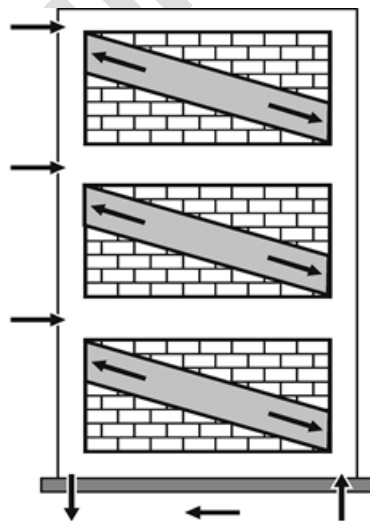

Figure C7.10: Compression strut analogy—eccentric struts (ASCE 41-13, 2014)

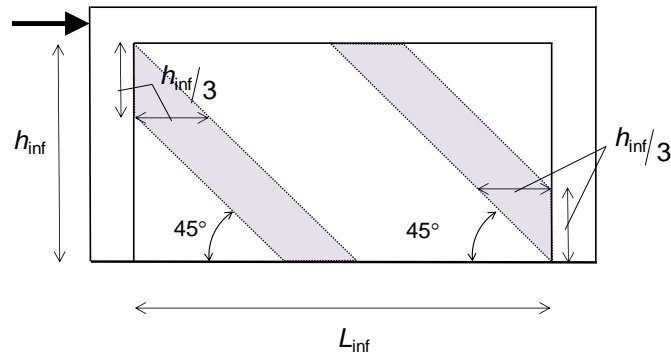

Figure C7.11: Compression strut analogy – struts at 45 degrees acting at the top of the left (windward) column and the bottom of the right (leeward) column for high aspect ratio infill panels (Stavridis, 2009)

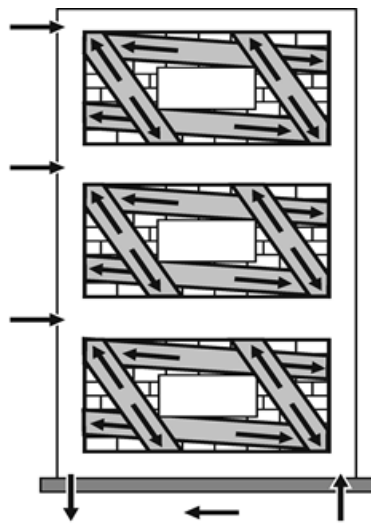

Figure C7.12: Compression strut analogy – penetrated infills (ASCE 41-13, 2014)

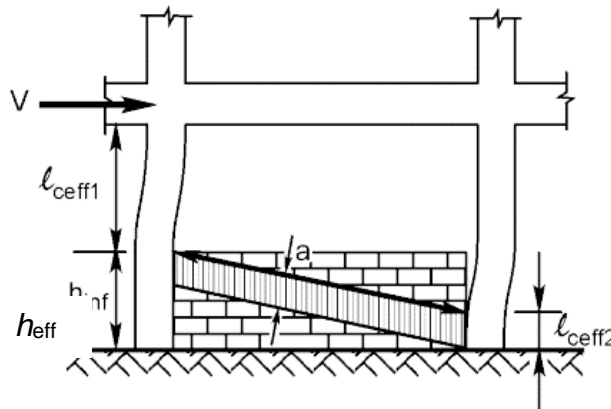

Figure C7.13: Compression strut analogy – partial infills

Because theoretical work and experimental data for determining multiple strut placement and strut properties are not sufficient to establish reliable guidelines for all possible infill configurations, the selection of the strut locations, widths and orientations needs judgement on a case-by-case basis. The engineer should be aware that if analytical models with frame elements are constructed to simulate the behaviour of infilled frames under seismic forces, the results can be significantly affected by the selected strut locations.

C7.7.1.2 Solid infill panels

The probable elastic in-plane stiffness of a solid masonry infill panel prior to cracking can be represented with an equivalent diagonal compression strut of width a , given by Equation C7.8 (Turgay et al., 2014). The equivalent strut should have the same thickness and modulus of elasticity as the infill panel it represents.

$$a = 0.18(\lambda_1 h_{\text{col}})^{-0.25} r_{\text{inf}} \quad \dots \text{C7.8}$$

where:

$$\lambda_1 = \left[\frac{E_m t \sin 2\theta}{4 E_f I_{\text{bc}} h_{\text{inf}}} \right]^{\frac{1}{4}}$$

and:

- h_{col} = column height between centre lines of beam (mm)
- h_{inf} = height of infill panel (mm)
- E_f = probable modulus of elasticity of frame material (MPa)
- E_m = probable modulus of elasticity of infill material (MPa)
- I_{bc} = moment of inertia in the plane of the infill for the bounding column (mm⁴)
- L_{inf} = length of infill panel (mm)
- r_{inf} = diagonal length of infill panel (mm)
- t = thickness of infill panel (mm)
- θ = angle whose tangent is the infill height-to-length aspect ratio (radians) given by the following:

$$\theta = \tan^{-1} \left[\frac{h_{\text{inf}}}{L_{\text{inf}}} \right] \quad \dots \text{C7.9}$$

Unless positive anchorage capable of transmitting in-plane forces from the frame members to all masonry wythes is provided on all sides of the walls, only the masonry wythes in full contact with the frame elements should be considered when computing in-plane stiffness.

Stiffness of cracked unreinforced masonry infill panels can be represented with equivalent struts. The strut properties should be determined from analyses that consider the nonlinear behaviour of the infilled frame system after the masonry is cracked.

C7.7.1.3 Penetrated infill panels

Note:

Experiments on perforated infill panels have shown that, under seismic forces, two sets of cracks develop at small lateral deformations and initiate the nonlinear behaviour. The first set is along the frame-infill boundary and the second set consists of cracks that initiate at the corners of openings and radiate into the infill at an angle close to 45 degrees. The stress field is clearly affected by the presence of the openings. However, the exact mechanism is still not clear.

A possible representation of these stress fields with multiple compression struts, as shown in Figure C7.12, has been proposed by Hamburger (1993). However, as theoretical work and experimental data for determining multiple strut placement and strut properties are not sufficient to establish reliable guidelines, assessment methods are as recommended below.

The in-plane stiffness of infills with openings should be assessed using rational strut and tie models using material properties given in other sections of this document, e.g. for concrete (in Section C5) and masonry (in Section C8). An alternative simplified approach for estimating the uncracked stiffness of perforated infill panel, K_{ini} , based on the stiffness of a frame with a solid panel is (ASCE 41-13, 2014):

$$K_{ini} = \left(1 - 2 \frac{A_{op}}{A_{wtot}}\right) K_{ini}^{solid} \quad \dots C7.10$$

where:

$$\begin{aligned} A_{op} &= \text{area of the opening in the infill panel} \\ A_{wtot} &= \text{gross area of an equivalent infill panel with no openings} \\ K_{ini}^{solid} &= \text{stiffness of an equivalent infill frame with a solid panel.} \end{aligned}$$

The in-plane stiffness of an equivalent infill frame with a solid panel, K_{ini}^{solid} , can be determined using the procedure detailed in Section C7.7.1.2.

C7.7.2 Probable in-plane strength

C7.7.2.1 General

Expected in-plane probable strength of a solid infill panel, V_{prob} , should be the lesser of the probable shear strength, V_{in} , and the probable corner crushing strength, V_{cc} , of the infill panel.

The compressive force in solid infill panels can be estimated assuming the development of one diagonal strut for aspect ratios smaller than 1.5 and two diagonal struts for larger aspect ratios (Stavridis, 2009). In the latter case, the force is distributed between the diagonal struts along 45 degree angles that initiate near the top of the windward column and the bottom of the leeward column (refer to Figure C7.11).

C7.7.2.2 Shear strength

For solid infill panels the probable infill shear strength, V_{in} , should be taken as the lower of the values given by Equations C7.11, C7.12 and C7.13 (Turgay et al., 2014):

$$V_{in} \leq 0.33\sqrt{f'_m}tL_{inf} \quad \dots C7.11$$

$$\leq 0.83tL_{inf} \quad \dots C7.12$$

$$\leq 0.41tL_{inf} + 0.45P \quad \dots C7.13$$

where:

$$\begin{aligned} f'_m &= \text{probable masonry compressive strength (MPa)} \\ L_{inf} &= \text{length of infill panel (mm)} \\ P &= \text{axial load on the infill (N)} \\ t &= \text{net thickness of infill panel (mm).} \end{aligned}$$

The net thickness of the infill panel, t , is the minimum thickness of the cross-sectional area of the panel. For a solid or fully grouted infill panel this is the total wall thickness. For unfilled or partially filled panels this is the net thickness of the masonry units.

Axial loads on the infill panel will be those due to gravity and the bounding action of the frame elements. When a gap is present at the top of the infill panel the former will typically be due to the self-weight of the panel and will therefore generally be small.

For the case when no gap is present at the top of the infill panel, the infill may also support tributary floor loads. In addition, when the bounding frame is of reinforced concrete construction creep effects can result in a transfer of gravity loads from the columns to the infill panels.

Axial loads due to the bounding action of the frame can be estimated from the following equation (FEMA 306, 1998):

$$P = \left(\Delta / h_{\text{inf}} \right)^2 t L_{\text{inf}} E_m \quad \dots \text{C7.14}$$

where:

E_m	=	probable modulus of elasticity of infill material (MPa)
L_{inf}	=	length of infill panel (mm)
h_{inf}	=	height of infill panel (mm)
P	=	axial load on the infill (N)
t_{inf}	=	thickness of infill panel (mm)
$t_{\text{net,inf}}$	=	net thickness of infill panel (mm)
Δ / h_{inf}	=	inter-storey drift angle (radians).
Δ	=	lateral deformation (deflection) of top of infill panel relative to base (mm)

Note:

Equations C7.11 to C7.13 are detailed in a paper by Turgay et al. (2014) for determining expected infill shear strength. These are identical to the equations described in section B.3.4.3 of TMS 402-11 (MSJC, 2011) except that the 1.5 denominator has been omitted. Analytical work by Turgay et al. (2014) demonstrated that the alternate expressions provide more reliable estimates of the probable infill shear strength when compared with ASCE 41-06 (2006) and TMS 402-11 (MSJC, 2011).

Review of the research completed by Turgay et al. (2014) suggests that Equation C7.13 will not typically govern the expected shear strength of infill panels. This is consistent with the work completed by Haldar et al. (2013) and Semnani et al. (2014).

C7.7.2.3 Corner crushing strength

The probable corner crushing strength, V_{cc} , of masonry infills should be taken as (Flanagan and Bennett, 2001):

$$V_{\text{cc}} = K t f'_m \quad \dots \text{C7.15}$$

where:

f'_m	=	probable masonry compressive strength (MPa)
K	=	empirical constant (mm)
t	=	net thickness of infill panel (mm).

Using the recommendation from Flanagan and Bennett (2001) the empirical constant, K , can be taken as 250 mm for steel and concrete frames with solid clay brick, clay tile and concrete masonry infill. This value provides a better estimate of the probable corner crushing strength when compared with TMS 402-11 (MSJC, 2011).

C7.7.2.4 Effect of reinforcement

If the infill panel is reinforced, the probable infill shear strength will be increased. The additional shear capacity associated with the infill panel reinforcement, V_s , can be taken as (FEMA 306, 1998):

$$V_s = \rho_w f_y t L_{inf} \quad \dots C7.16$$

where:

- ρ_w = volumetric ratio of the infill panel reinforcement
- f_y = probable yield strength of the infill panel reinforcement (MPa)
- L_{inf} = length of infill panel (mm)
- t = thickness of infill panel (mm).

Volumetric ratio of the infill panel reinforcement, ρ_w , used in Equation C7.16 can be taken as the minimum associated with the horizontal or vertical panel reinforcement.

C7.7.3 Generalised strength-deformation relationships

Figure C7.14 illustrates the generalised strength-deformation relationship for masonry infill panels where V_E is the probable shear strength of the infill panel. Probable drift capacities (%) for masonry infill panels are given in Table C7.1 below.

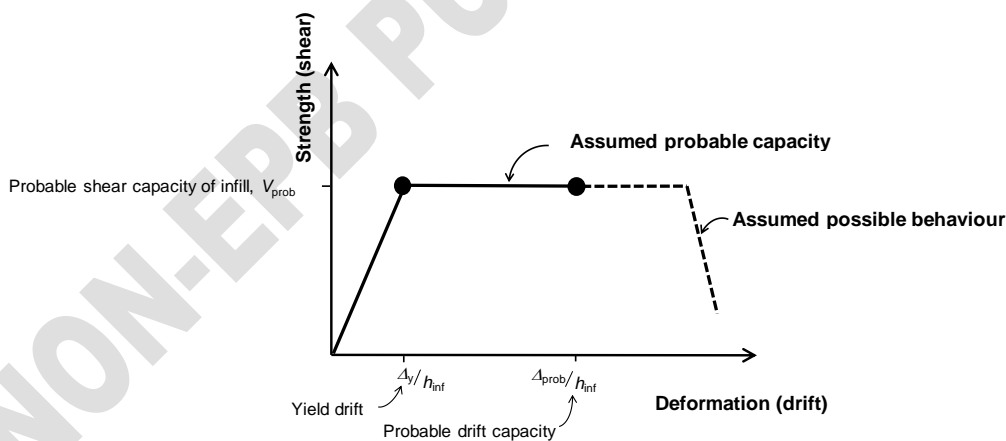

Figure C7.14: Generalised strength-deformation relationship for masonry infill panels

Table C7.1: Probable deformation (drift) capacity of infill panels

$\beta = \frac{V_{fre}}{V_{prob}}$	$\frac{L_{inf}}{h_{inf}}$	Residual strength ratio C	Probable drift capacities (%)
$1.0 \leq \beta < 1.3$	0.5	N/A	0.70
	1.0	N/A	0.55
	2.0	N/A	0.40
$\beta \geq 1.3$	0.5	N/A	1.00
	1.0	N/A	0.80
	2.0	N/A	0.60

Note:

- Interpolation can be used between table values.

When establishing the probable drift capacity of an infill panel, the ratio of the frame to infill strength, β , should be determined considering the expected lateral strength of each element. V_{fre} is the expected storey probable shear strength of the bare frame, taken as the probable shear capacity of the column calculated in accordance with Section C7.8.7. V_{prob} is the probable in-plane infill strength calculated in accordance with Section C7.7.2.

Note:

The generalised deformation values in Table C7.1 have been sourced from ASCE 41-13 (2014). However, the ASCE 41-13 (2014) deformation limits have been divided by 1.5 to ensure that an appropriate margin is provided against collapse of the masonry infill panel.

Probable capacities for structural steel or reinforced concrete frame members that surround the infill panels should be as recommended in Sections C5 and C6 of this document except as modified in Section 0 below.

C7.8 Influence of Infill Panels on Frame Members

C7.8.1 General

The flexural and shear strength assessment of any structural steel or reinforced concrete frames that surround infill panels should be based on Sections C5 and C6 of this document, including consideration of related seismic demands on beam-column joints, except as modified below. It is emphasised that the presence of infills modifies and magnifies the shear demands on the frame members by shortening the distance between in-span plastic hinges.

Experience from field observations and experimental work suggests that beams are less susceptible to damage when compared with columns.

As the demands on the bounding members are dependent on the strut size some iteration may be required in the calculations outlined below.

C7.8.2 In-plane shear demands on columns adjacent to solid infill panels

The maximum expected flexural and shear demands on columns adjacent to solid infill panels can be estimated by application of the horizontal component of the expected strut force at a distance of l_{ceff} from the top or bottom of the panel as illustrated in Figure C7.15 below. The effective length, l_{ceff} , may be found from:

$$l_{\text{ceff}} = \frac{a}{\cos \theta_c} \quad \dots \text{C7.17}$$

where:

a = the equivalent strut width calculated in Section C7.7.1 above and $\tan \theta_c$ can be found by solving the following equation:

$$\tan \theta_c = \frac{h_{\text{inf}} - \left(\frac{a}{\cos \theta_c} \right)}{L_{\text{inf}}} \quad \dots \text{C7.18}$$

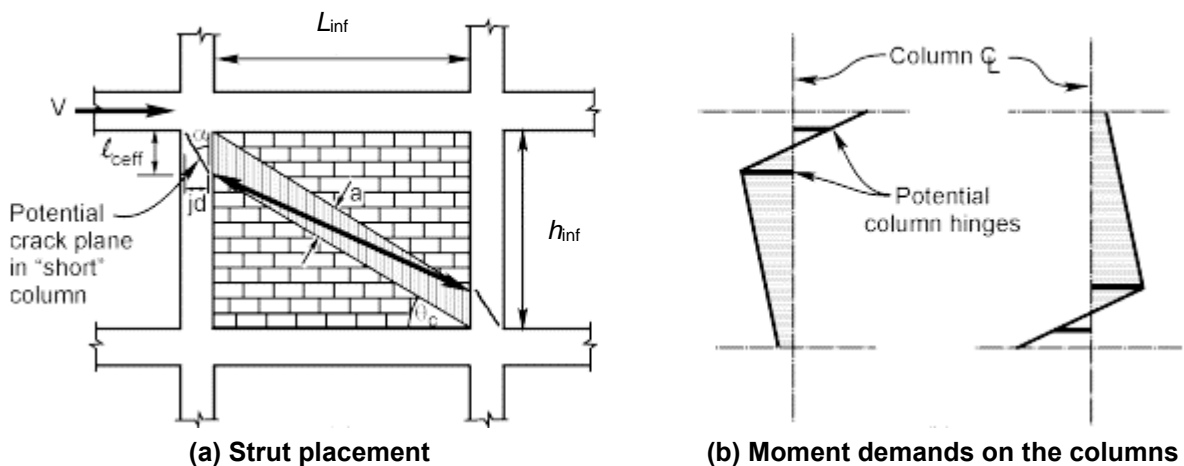

Figure C7.15: Estimating infill strut demands on columns

An upper bound maximum column shear demand when plastic hinges form in the column can be estimated as:

$$V_{\text{col}} = \frac{2M_0^{\text{col}}}{l_{\text{ceff}}} \quad \dots\text{C7.19}$$

where:

$$M_0^{\text{col}} = \text{overstrength moment capacity of the column.}$$

C7.8.3 In-plane shear demands on columns adjacent to partial height infill panels

The maximum expected flexural and shear demands on columns adjacent to partial height infill panels can be estimated by application of the horizontal component of the expected strut force at a distance of l_{ceff1} from the top of the panel and l_{ceff2} from the bottom of the panel as illustrated in Figure C7.13.

The effective length of the “leeward” column, l_{ceff2} , and associated shear demands can be determined using the procedure detailed in the previous section. For the “windward” column (the left column in Figure C7.13) the effective length, l_{ceff1} , can be estimated as:

$$l_{\text{ceff1}} = h_{\text{col}} - h_{\text{inf}} \quad \dots\text{C7.20}$$

C7.8.4 In-plane shear demands on beams adjacent to solid infill panels

The maximum expected flexural and shear demands on beams adjacent to solid infill panels can be estimated by application of the vertical component of the expected strut force at a distance of l_{beff} from each end of the panel as illustrated in Figure C7.16 below. The effective beam length, l_{beff} , may be found from:

$$l_{\text{beff}} = \frac{a}{\sin \theta_b} \quad \dots\text{C7.21}$$

where:

a = the equivalent strut width calculated in Section C7.7.1 above and $\tan \theta_b$ can be found by solving the following equation:

$$\tan \theta_b = \frac{h_{\text{inf}}}{\left(L_{\text{inf}} - \left(\frac{a}{\sin \theta_b} \right) \right)} \quad \dots\text{C7.22}$$

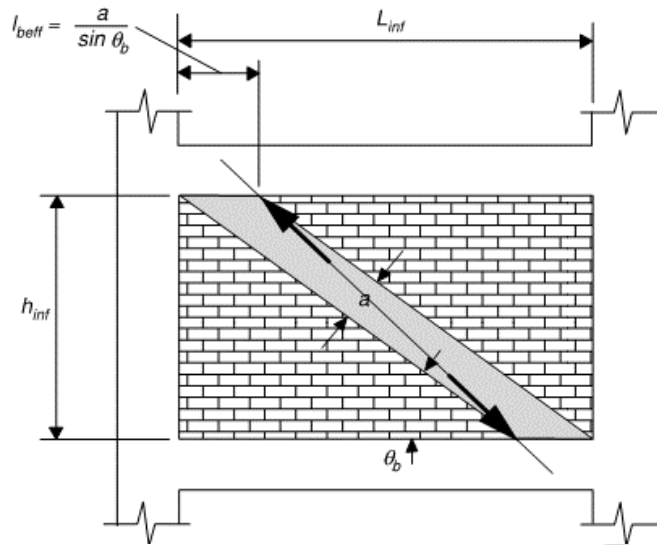

Figure C7.16: Estimating infill strut demands on beams (FEMA 306, 1998)

An upper bound maximum beam shear demand when plastic hinges form in the beam, including effects of tributary slab steel if present, with a reduced length equal to l_{beff} can be estimated as:

$$V_{beam} = \frac{2M_o^{beam}}{l_{beff}} \quad \dots C7.23$$

where:

M_o^{beam} = is the overstrength moment capacity of the beam.

Note:

Experience from field observations and experimental work suggests that when a beam is confined by infill panels above and below, and when no gap is present between the top of the wall and the bottom of the beam, in most typical situations the in-plane shear demands on the beam will be limited and this failure mechanism is unlikely to occur.

C7.8.5 In-plane shear demands on beams and columns adjacent to perforated infill panels

Because theoretical work and experimental data for determining multiple strut placement and strut properties are not sufficient to establish reliable guidelines for all possible infill configurations, the determination of maximum expected flexural and shear demands on beams and columns with perforated infills requires judgement on a case-by-case basis. Procedures detailed in Sections C7.7.1.2 and C7.7.1.3 can be adapted to suit the alternate strut locations discussed in Section C7.7.1.3.

C7.8.6 In-plane tension demands on beam to column connections

The horizontal component of compression force from the infill diagonal compression strut will impose tension forces in the beam to column connection between a beam and an exterior column. This tension force and associated deformation may be sufficient to degrade the vertical load carrying capacity of the beam to column connection.

An assessment of the horizontal component of tension force through the connection needs to be made and compared with the tension capacity of the beam to column connection, to determine if such a failure mode is likely.

C7.8.7 Modified shear capacity

C7.8.7.1 Structural steel frame members

The probable shear capacity of steel frame members can be determined in accordance with Section C6 of this document.

For steel frames with solid webs shear failure of the frame members may not be a critical mode of failure due to the ductility of solid steel webs in shear. The shear capacity of laced and battened encased steel columns is more problematical and dependent on the type and capacity of the ties between the column members.

C7.8.7.2 Reinforced concrete frame members

For shear-critical reinforced concrete frame members, a corner-to-corner crack angle is expected to form between the hinges.

Equation deleted ...C7.24

Equation deleted ...C7.25

The probable shear capacity of [concrete](#) frame members can be determined in accordance with Section C5. [The effective column length including influence of the infill should be considered when determining the shear span \(\$M^*/V^*\$ \).](#)

C7.8.8 Bond slip of lap-splice connections in reinforced concrete frame members

Lap-splice connections of column longitudinal reinforcing steel are often present at the base of reinforced concrete columns. Their seismic behaviour can be determined in accordance with Section C5.

Note:

Providing that the lap length is sufficient to develop the expected yield strength of the reinforcing steel, the moment capacity of the section can be attained. However, post elastic deformations quickly degrade the bond-strength capacity, and within one inelastic cycle of loading the lap splice should be assumed to have become ineffective (FEMA 306, 1998).

C7.9 Improving the Seismic Performance of Moment Resisting Frames with Masonry Infill Panels

C7.9.1 Improving out-of-plane performance

Techniques for improving the out-of-plane seismic performance of moment resisting frames with masonry infill panels include:

- providing supplementary vertical mullions
- strengthening the infill wall using reinforced concrete overlays
- strengthening the infill wall using fibre reinforced polymer (FRP) overlays or near surface mounted FRP strips (note that FRP strips will be required on both sides)
- strengthening the infill wall using engineered cementitious composite (ECC) shotcrete overlays
- removing the infill wall.

C7.9.2 Improving in-plane performance

Techniques for improving the in-plane seismic performance of moment resisting frames with masonry infill panels include:

- strengthening the infill wall using reinforced concrete overlays
- strengthening the infill wall using FRP overlays or near surface mounted FRP strips
- strengthening the infill wall using ECC shotcrete overlays
- filling excessively sized infill wall openings with appropriate materials
- providing additional transverse reinforcement to deficient frame members to increase shear capacity, confinement and/or lap-splice continuity
- jacketing deficient frame elements to increase flexural capacity
- providing supplementary lateral load resisting systems to, for example, new reinforced concrete shear walls or structural steel braced frames
- removing the infill wall or isolating the infill wall from the frame elements
- strengthening the tension capacity of beams to external columns in infilled steel frames where required.

When providing supplementary lateral load resisting systems to improve the global performance of the structure (one of the suggestions above) deformation compatibility effects need to be considered. The new supplementary lateral load resisting elements should be detailed to have sufficient strength and stiffness so the seismic demands on the existing infill frame are limited to the required levels.

In many circumstances, this will mean that new structural braced frames or reinforced concrete shear walls are required: in other words, new moment resisting frames are unlikely to be stiff enough.

References

- Al-Chaar, G., Mehrabi, A.B. and Manzouri, T. (2008). *Finite element interface modeling and experimental verification of masonry-infilled R/C frames*, The Masonry Society Journal, Vo. 26(1), 47-65.
- Angel, R., Abrams, D.P., Shapiro, D., Uzarski, J. and Webster, M. (1994). *Behaviour of reinforced concrete frames with masonry infills*, Department of Civil Engineering, University of Illinois at Urbana-Champaign, Illinois, Civil Engineering Studies, Structural Research Series No. 589, March 1994.
- ASCE 41-06 (2006). *Seismic rehabilitation of existing buildings*, American Society of Civil Engineers, and Structural Engineering Institute, Reston, Virginia, USA.
- ASCE 41-13 (2014). *Seismic evaluation and retrofit of existing buildings*, American Society of Civil Engineers, and Structural Engineering Institute, Reston, Virginia, USA.
- Agenti, N., and Parisi, F. (2010). *Learning from construction failures due to the 2009 L'Aquila, Italy, earthquake*, ASCE Journal of Performance of Constructed facilities, 24(6), 536-555.
- Braga, F., Manfredi, V., Masi, A., Salvatori, A. and Vona, M. (2011). *Performance of non-structural elements in RC buildings during the L'Aquila, 2009 earthquake*, Bulletin of Earthquake Engineering, Vol. 9, No. 1, 307-24.
- Dawe, J.L. and Seah, C.K. (1989). *Out-of-plane resistance of concrete masonry infilled panels*, Canadian Journal of Civil Engineering, 16(6), 854-864.
- FEMA 306 (1998). *Evaluation of earthquake damaged concrete and masonry wall buildings – Basic Procedures Manual*, Applied Technology Council, Redwood City, California.
- Flanagan, R.D. and Bennett, R.M. (1999). *Arching of masonry infilled frames: comparison of analytical methods*, ASCE Practice Periodical on Structural Design and Construction, 4(3), 105-110.
- Flanagan, R.D. and Bennett, R.M. (2001). *In-plane analysis of masonry infill panels*, Practice Periodical on Structural Design and Construction, American Society of Civil Engineers, Reston, Virginia.
- Haldar, P., Singh, Y. and Paul, D.K. (2013). *Identification of seismic failure modes of URM infill RC frame buildings*, Engineering Failure Analysis, Elsevier, 2013.
- Hamburger, R.O. (1993). *Methodology for seismic capacity evaluation of steel-frame buildings with infill unreinforced masonry*, Proceedings of the 1993 National Earthquake Conference, Central U.S. Earthquake Consortium, Memphis, Tennessee, Vol. II, 173-191.
- Kam, W.Y., Pampanin, S. and Elwood, K. (2011). *Seismic performance of reinforced concrete buildings in the 22 February Christchurch (Lyttelton) earthquake*, Bulletin of the New Zealand Society for Earthquake Engineering, Vol. 44, No. 4, 239-278, December 2011.
- Mays, G.C., Hetherington, J.G. and Rose, T.A. (1998). *Resistance-deflection functions for concrete wall panels with openings*, ASCE Journal of Structural Engineering, 124(5), 579-587.
- MSJC (2011). TMS 402-11: *Building code requirements for masonry structures*, Masonry Joint Standards Committee, Reston, Virginia.
- NZS 1170.5:2004. *Structural design actions, Part 5: Earthquake actions – New Zealand*, Standards New Zealand, Wellington, NZ.
- NZS 3101:2006. *Concrete structures standard*, Standards New Zealand, Wellington, NZ.
- NZS 4203:1992. *General structural design and design loads for buildings*, Standards New Zealand, Wellington, NZ.
- NZS 4230:2004. *Design of reinforced masonry structures*, Standards New Zealand, Wellington, NZ.
- NZSS 1900:1965. Chapter 8, *Basic design loads*, New Zealand Standard Model Building Bylaw, Standards Institute, Wellington, NZ.
- Paulay, T. and Priestley, M.J.N. (1992). *Seismic design of reinforced concrete and masonry buildings*, John Wiley and Sons, New York.
- Semnani, S.J., Rodgers, J.E. and Burton, H.V. (2014). *Conceptual seismic design guidance for new reinforced concrete framed infill buildings*, GeoHazards International, Menlo Park.
- Stavridis, A. (2009). *Analytical and experimental study of seismic performance of reinforced concrete frames with masonry walls*, PHD Dissertation, University of California, San Diego.
- Turgay, T., Durmus, M.C., Binici, B. and Ozcebe, G. (2014). *Evaluation of the predictive models for stiffness, strength and deformation capacity of RC frames with masonry infill walls*, ASCE Journal of Structural Engineering, 06014003, 1-9.
- Verderame, G.M., Iervolino, I. and Ricci, P. (2009). *Report on the damages on buildings following the seismic event of the 6th of April 2009*, V1.20, <http://www.reluis.it>.